

Kugelhähne aus Edelstahl

stainless steel ball valves

**Baureihe
835**

**mit vollem Durchgang
full port design**

G 1/4 - G 2



Trinkwasser
NW-6102BO0271

Konstruktions-Merkmale

- zweiteiliges Gehäuse, verschraubt
- voller Durchgang
- ausblassichere Schaltwelle
- einstellbare Stopfbuchse
- Innengewinde nach ISO 228-1
- Entlastungsbohrung von DN25-DN50

Material

Gehäuse:	Edelstahl 1.4408
Kugel:	Edelstahl 1.4408
Kugeldichtung:	PTFE
Schaltwelle:	Edelstahl 1.4401
Schaltwellendichtung:	PTFE
Griff:	<ul style="list-style-type: none">• Edelstahl mit grüner Kunststoffummantelung• Flügelgriff Alu grün bis DN 32• ISO-T-Griff grau

Temperaturbereich

- 20° C bis max. + 180° C
ISO- T Griff - 30°C bis + 150°C
kurzzeitig bis + 170°C
(abhängig vom Betriebsdruck)
Kalt- und Warmwasser

Verwendung

Wasser, Öl, Druckluft, Kraftstoffe,
Lösungsmittel, Dampf, aggressive Medien, Lebens-
mittel, Getränke
Trinkwasserinstallation PN10

Bemerkung

Stopfbuchsmutter muß in zeitlichen Abständen
nachgezogen werden.
Trinkwasserzulassung nach DIN EN 13828
und DVGW W 570

Design features

- two - piece ball valve "screwed design"
- full port design
- blow out proof stem design
- adjustable stem packing
- female thread acc. to ISO 228-1
- vent bore from DN25-DN50

materials

body:	stainless steel 1.4408
ball:	stainless steel 1.4408
ball seal:	PTFE
stem:	stainless steel 1.4401
stem packing:	PTFE
handle:	<ul style="list-style-type: none">• stainless steel with green plastic cover• T-handle green up to DN 32• ISO-T-handle grey

working temperature

- 20° C to max. + 180° C
ISO- T handle - 30°C to + 150°C
momentary + 170°C
(depending on working pressure)
cold and hot water

suitable for

water, oil, compressed air, fuels,
solvents, steam, aggressive mediums,
food, beverages
tube system for drinking water PN10

remark

gland nut must be adjusted in intervals.

drinking water registered acc. to DIN EN 13828
and DVGW W 570

835

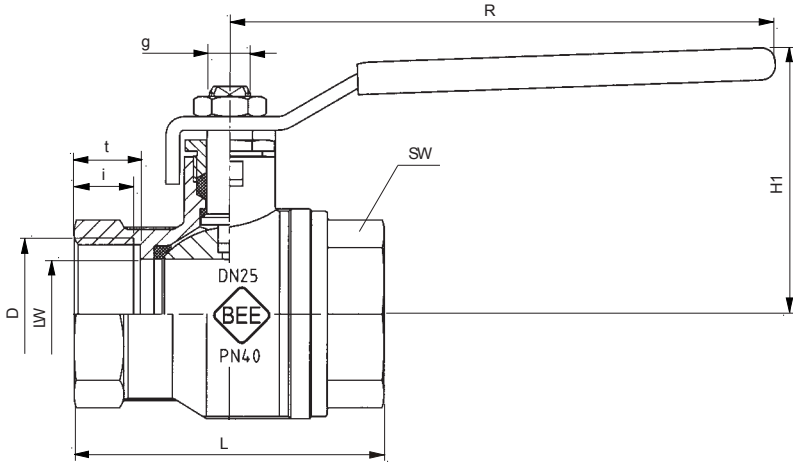

835.2

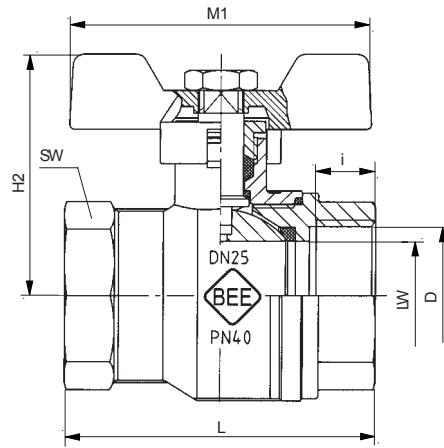

835T

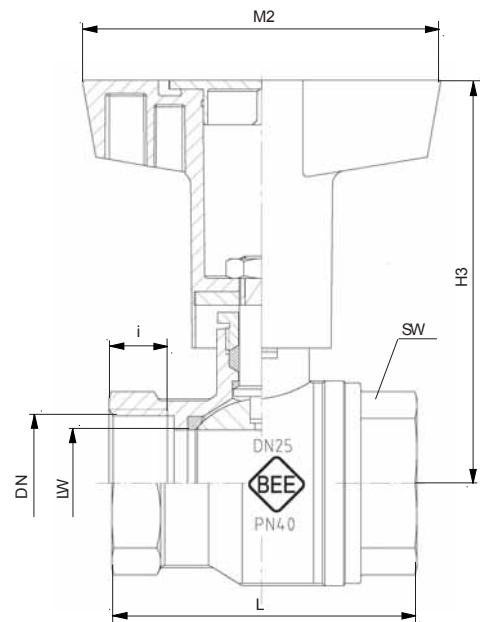

**Druck-Temperaturdiagramm
pressure-temperature diagram**

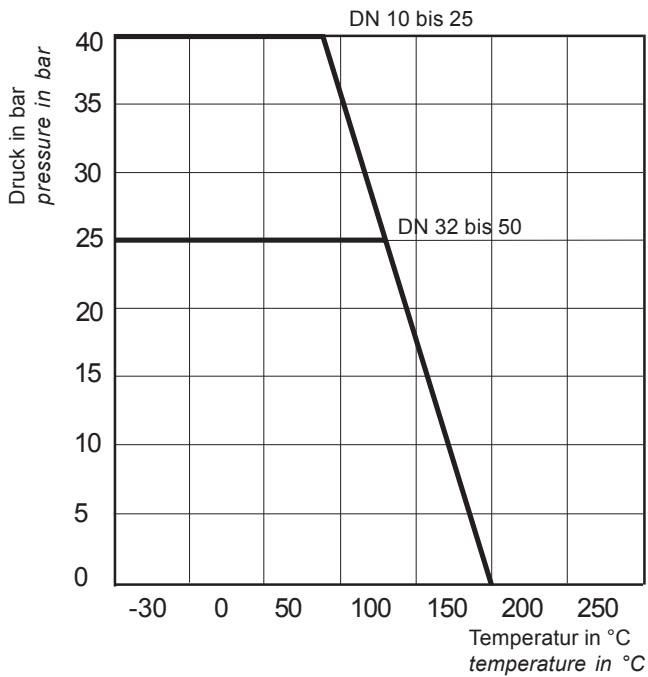

**Bestellbeispiel
ordering example**

Kugelhahn beiderseits Innengewinde mit Flügelgriff 1/2
ball valve female / female thread
with T-handle 1/2

835.2 - 1/2

i = nutzbare Gewindetiefe, useable length of thread

Maße in mm, dimensions in mm

DN	LW	PN (bar)	D ISO-228-1	i	t	L ± 2	g	H1 ~	R	H2	M1	H3	M2	SW	Gewicht weight ~ kg	
6	9	40	G 1/4	8,5	10	40	1/4-20UNC	40	82	40	50	74,5	70	20	6 kant	0,128
10	9	40	G 3/8	8,5	10	40	1/4-20UNC	40	82	40	50	74,5	70	20	6 kant	0,118
15	14	40	G 1/2	10	11,5	50	5/16-18UNC	45	100	44,5	60	74,5	70	25	8 kant	0,184
20	19	40	G 3/4	11	12,5	60	5/16-18UNC	49	100	48,5	60	78,5	70	31	8 kant	0,308
25	24	40	G 1	13	14,5	68	3/8-16UNC	57	120	53	66	90,5	80	38	8 kant	0,458
32	30	25	G 1 1/4	14	15,5	80	3/8-16UNC	62	120	58,4	66	95,5	80	48	8 kant	0,738
40	38	25	G 1 1/2	16	17,5	94	M12x1,25	80	160			122,5	120	54	8 kant	1,235
50	47	25	G 2	17	18,5	106	M12x1,25	87	160			130,5	120	66	8 kant	1,970